

VIB 2000 GF



VIB 2000 GF - Stand 10.04.2000

Characteristics and sound properties

The VIB 2000 GF is the logical development of one of the most popular column cabinets in the field of D.I.Y. speakers – the VISATON VIB. The concept of the 2-way enclosure in a 45 litre vented cabinet has been retained, but the drivers used are different, and the crossover unit has been reappraised to suit. In the low-to mid-range we have the GF 200 2 x 4 Ohm, whose fibre glass cone can produce a big stroke and thus is good for powerful low-range bass even at higher volume levels. The parallel resonant circuit before the low pass unit compensates for the rise in the mid-range of the 200 mm cone drive and guarantees a linear and coloration-free frequency response until the tweeter takes over at around 2.5 KHz. The 18 dB high-pass section links in the 25 mm G 25 FFL 8 Ohm textile dome unit. The VIB 2000 GF produces remarkably vivid, precise bass output at the lowest frequencies, linear mid-range sound, spatially separated from the speakers themselves and a smooth, finely sketched high-frequency range.

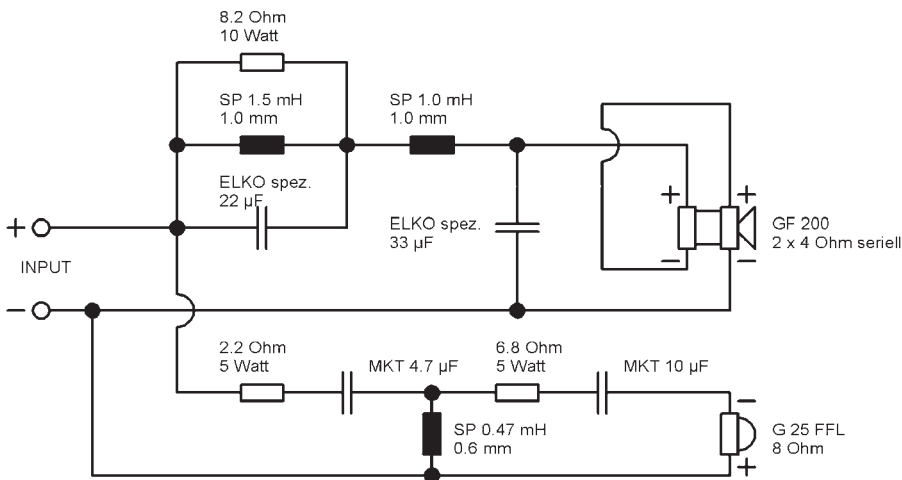

Technical Data:

Nominal power handling: 80 Watt
 Peak power handling: 110 Watt
 Nominal impedance: 8 Ω
 Frequency response: 35 – 30.000 Hz
 Mean sound pressure (nominal): 86 dB (1 W/1 m)
 Cut-off frequency: 2500 Hz

Principle of Housing: Bassreflex

Net volume: 45 l
 Outer dimension: height: 919 mm
 width: 248 mm
 depth: 296 mm

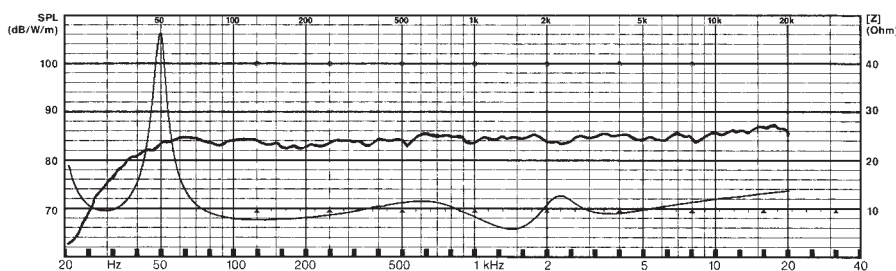

Component parts list for 1 box:

Notwendige Bauteile:

Tweeter:	G 25 FFL	8 Ω	
			1 piece
Low-midrange driver:	GF 200	8 Ω	
			1 piece
Crossover:	„VIB 2000 GF“		
Bass reflex tube:	BR 15.34	1 piece	
	(length 14,7 cm)		
Terminal:	ST 77	1 piece	
Damping material:		2 bags	
Wood screws:			
	3,5 x 25 mm		8 pieces
	4 x 20 mm		6 pieces
Cable:	2 x 1,5 mm ²		2 m

Cabinet parts list for 1 box

Material: 19 mm chipboard or MDF

Parts	Size (mm)	Quantity
Front and rear panel	210 x 862	2
Front and rear panel	900 x 296	2
Top and bottom panel	210 x 296	2
Versteifung		
Brace	210 x 100	2
Brace	258 x 100	2
Base panel	258 x 210	1

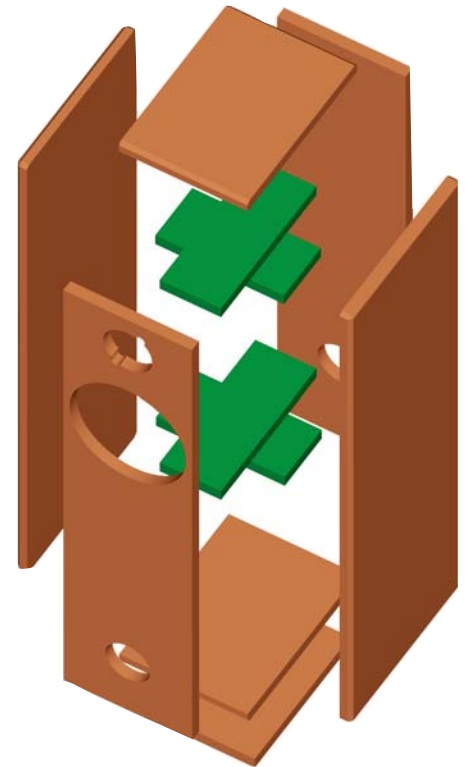

Building instructions

The circular cut-out (73 mm \varnothing) in the baffle is for the BR 15.34 tube. The 78 mm cut-out in the rear panel is for mounting the ST 77 terminals. The crossover unit is mounted on the panel behind the bass cut-out.

Inner damping

The damping is a simple matter: as shown in the diagram, the four free square openings of the stiffening construction take one mat each, so that the upper part of the speaker cabinet is loosely filled. The lower part is left completely empty.

